

# ALL TERRAIN CRANE

ZAT1500  
PRODUCT MANUALS

Zoomlion Lifting Machinery Company



ZOOMLION

**ZOOMLION LIFTING MACHINERY COMPANY**

Address: Zoomlion Quantang Industrial Park, Changsha Economic-Technological Development Zone, China  
Find out more details at: [en.zoomlion.com](http://en.zoomlion.com) Copyright © 2014 Zoomlion. All Rights Reserved.  
Reproduction and copying any part of the Contents is not allowed for any purposes without Zoomlion's written approval.



ZOOMLION

Vision Creates Future

---

## **CONTENTS**

---

ZAT1500 Lifting capacity	01 / 02
ZAT1500 Technical data	03 / 04
ZAT1500 Overall view / Lifting height chart	03 / 04
ZAT1500 Rated lifting capacity table	05 / 14
ZAT1500 Lifting height chart	15 / 16

---







72

Max. lifting height of main boom

87

Max. lifting height of top

7.8×8.43

Outrigger spread (W×L)



## ZAT1500 Lifting capacity

- This high-tech product, combining mechanical, electrical and hydraulic systems as a whole, has so many advantages, such as good control performance, excellent micro-positioning performance, great lifting capacity and super lifting height, that it is active in various fields.
- The 5-axle (3 axles driven and all axles steered) full-width special purpose chassis is manufactured by Zoomlion, providing wide vision, spacious cab and luxurious decoration.
- The latest electro-hydraulic proportional directional control valve with load sensing function, multiple plunger variable pumps and open / closed variable system ensure that each executive mechanism makes full use of its work capability.
- The safety devices, such as relief valve, balance valve, hydraulic lock and brake valve, etc. in the hydraulic system, are against rupture of pipes and hoses.



## ZAT1500 Technical data

Item	Value	Remarks	
Working performance	Max. rated lifting capacity	kg 150000	At 3 m radius
	Max. load moment of basic boom	kN.m 4704	At 6 m radius
	Max. load moment of main boom (fully extended)	kN.m 1505	At 32 m radius
	Max. lifting height of basic boom	m 13.0	
	Max. lifting height of main boom	m 72	
	Max. lifting height of jib	m 87/(95)	
Working speeds	Max. hoist rope speed (Main winch)	m/min. 114	
	Max. hoist rope speed (Auxiliary winch)	m/min. 74	At the 4 <sup>th</sup> layer
	Boom derricking up time	s 94	At the 3 <sup>rd</sup> layer
	Boom extending time	s 860	
	Max. slewing speed	r/min. 1.4	
	Max. height above sea level	m 2000	
Driving	Max. driving speed	km/h 75	
	Max. gradeability	% 40	
	Min. turning diameter	m ≤ 20	
	Min. ground clearance	mm 305	
	Limits for exhaust pollutants and smoke	Conform to related standards	GB3847-2005/GB17691-2005 (National Stage IV)
	Fuel consumption per hundred kilometers	L 76	
Mass	Deadweight in driving condition	kg 60000	
	Complete vehicle kerb mass	kg 59805	
	Load on axles 1, 2 and 3	kg 12000	
	Load on axles 4 and 5	kg 12000	
	Overall dimensions (L × W × H)	mm 15390 × 3000 × 4000	
	Outrigger spread (L)	m 8.43	
Dimension	Outrigger spread (W)	m 7.8(fully extended), 5.3(intermediately extended)	
	Main boom length	m 13.5 – 72	
	Boom angle	° -0.5 – 82	
	Jib length	m 11, 18.6	
	Jib + extension length	m 26.6	
	Offset	° 0, 30	

## ZAT1500 Overall view / Lifting height chart

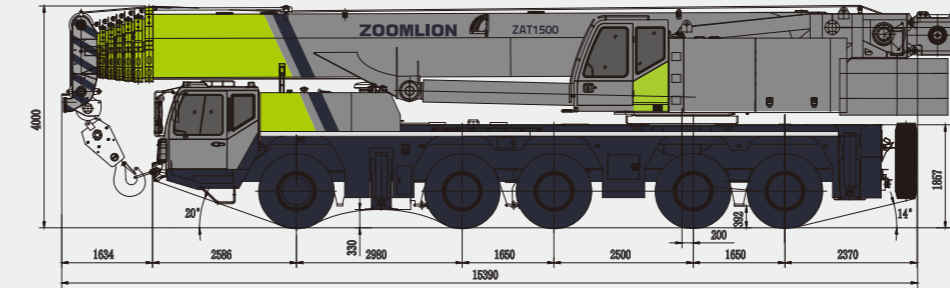

Unit: Metric mm

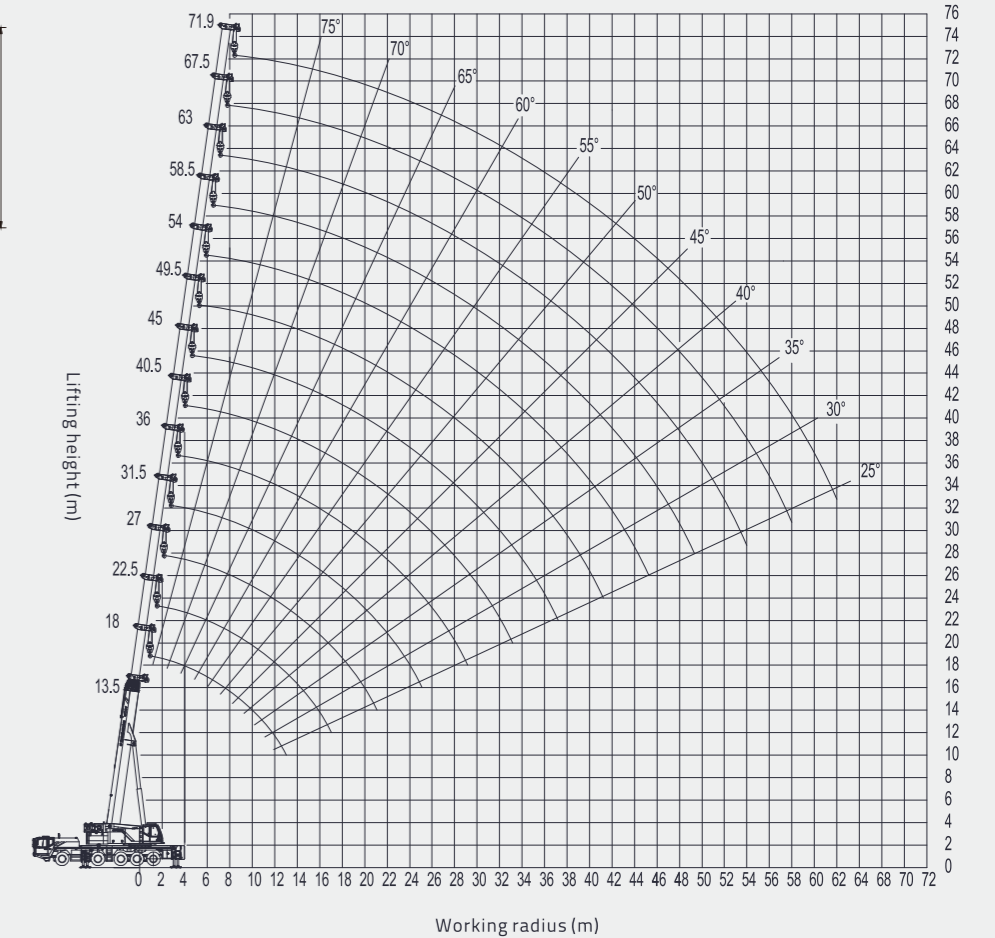



# ZAT1500 Rated lifting capacity table

Table 1 Main boom Unit: Metric tons

Radius (m)	Outriggers fully extended, with 45 tons counterweight, over full range														
	Boom length (m)														
3	150*	100*	90												
3.5	105*	95*	87	75											
4	100*	90	83	75											
4.5	96*	85	78	75	60										
5	92*	80	73	70	58										
5.5	86	75	68	65	55	45									
6	80	70	63	60	52	45									
7	67	65	58	55	49	45	35								
8	58	58	53	50	46	43	33								
9	50	50	47	43	41	30.5	28								
10		44	44	44	40	38	29	28							
11		39	39	39	37.5	35.5	27.5	26	23						
12		35	35	35	33	26	24	21.5	19						
14			29	29.5	32.5	29	23.5	21.4	19	17	15				
16			23	23.6	24.6	25	21.5	19.2	17.2	15.4	13.5	12			
18				19.6	20.4	21	19.5	17	15.6	13.9	12.5	11	9		
20				16.4	17.2	18	17.6	15.2	14	12.6	11.5	10.1	8.2	7	
22					14.5	15	15.4	13.8	12.4	11.3	10.5	9.3	7.6	6.5	
24					12.4	13	13.6	12.4	11.2	10.2	9.5	8.5	7.1	6.1	
26						11.2	11.8	11	10.2	9.2	8.6	7.8	6.6	5.7	
28						9.8	10.4	9.8	9.4	8.4	7.9	7.2	6.2	5.4	
30							9.2	8.6	8.6	7.6	7.2	6.7	5.8	5.1	
32							8.2	7.6	7.6	7	6.5	6.2	5.4	4.8	
34								6.7	6.7	6.4	5.9	5.7	5	4.5	
36								5.9	5.8	5.4	5.2	4.7	4.2	3.7	
38									5.2	5.2	5	4.7	4.4	3.9	
40									4.6	4.6	4.6	4.4	4.1	3.7	
42									4.0	4.2	4.1	3.8	3.5	3.1	
44										3.5	3.7	3.9	3.6	3.2	
46											3.3	3.6	3.4	3	
48												2.9	3.2	2.8	
50													2.8	2.6	
52													2.4	2.4	
54													2.3	2.2	
56													2.1	2	
58														1.8	
60														1.6	
Reeving	14	14	12	10	8	6	5	4	3	3	2	2	2	2	
Hook	90 tons			55 tons				25 tons							
Telescoping mode	I	1	1	1	2	2	2	3	3	3	3	3	3	4	
	II	1	2	2	2	2	2	2	3	3	3	3	3	4	
	III	1	1	2	2	2	2	2	3	3	3	3	3	4	
	IV	1	1	1	2	2	2	2	2	3	3	3	3	4	
	V	1	1	1	1	1	2	2	2	2	2	3	3	4	
	VI	1	1	1	1	1	2	2	2	2	2	3	3	4	

Note: The data indicated with an asterisk (\*) are suitable for 110 tons hook. (The data "150" is the nominal lifting capacity.)

Table 2 Main boom Unit: Metric tons

Radius (m)	Outriggers fully extended, with 32 tons counterweight, over full range															
	Boom length (m)															
3	110*	100*	90													
3.5	105*	95*	87	75												
4	100*	90	83	75												
4.5	94*	85	78	75	60											
5	88	80	73	70	58											
5.5	82	75	68	65	55	45										
6	76	70	63	60	52	45										
7	62	61	58	55	49	45	35									
8	53	53	53	50	46	43	33									
9	46	46	46	46	43	41	30.5	28								
10		40	40	40	40	38	29	28								
11		35	35	35	36	35.5	27.5	26	23							
12		31	31	30.5	31	32	26	24	21.5	19						
14			24	23.5	24	25	23.5	21.4	19	17	15					
16				19	18.5	19	20	21	19.2	17.2	15.4	13.5	12			
18					15	15.5	16	17	16.5	15.6	13.9	12.5	11	9		
20						12	13	13.5	14.5	13.8	12.6	11.5	10.1	8.2	7	
22							10.5	11	12	11.5	11.5	11.3	10.5	9.3	7.6	6.5
24							9	9.5	10.5	10	10	10	9.5	8.5	7.1	6.1
26								8.2	9	8.5	8.5	8.6	8.6	7.8	6.6	5.7
28								7.2	8	7.4	7.4	7.5	7.8	7.2	6.2	5.4
30									6.8	6.3	6.3	6.4	6.7	6.7	5.8	5.1
32									6	5.4	5.4	5.5	5.8	6.1	5.4	4.8
34										4.6	4.6	4.7	5	5.3	5	4.5
36										3.9	3.9	4	4.3	4.6	4.6	4.2
38											3.3	3.4	3.7	4	4.2	3.9
40											2.7	2.9	3.2	3.5	3.8	3.7
42												2.4	2.7	3	3.4	3.4
44												1.9	2.2	2.5	2.9	3
46													1.8	2.1	2.4	2.5
48													1.4	1.7	2.1	2.2
50														1.4	1.7	1.8
52															1.4	1.5
54															1.1	1.2
Reeving	14	14	12	10	8	6	5	4	3	3	2	2	2	2	2	
Hook	90 tons			55 tons				25 tons								
Telescoping mode	I	1	1	1	2	2	2	3	3	3	3	3	3	3	4	
	II	1	2	2	2	2	2	2	2	3	3	3	3	3	4	
	III	1	1	2	2	2	2	2	2	3	3	3	3	3	4	
	IV	1	1	1	2	2	2	2	2	2	3	3	3	3	4	
	V	1	1	1	1	1	2	2	2	2	2	2	3	3	4	
	VI	1	1	1	1	1	2	2	2	2	2	2	3	3	4	

Note: The data indicated with an asterisk (\*) are suitable for 110 tons hook.

# ZAT1500 Rated lifting capacity table

Table 3 Main boom Unit: Metric tons

Radius (m)	Outriggers fully extended, with 24 tons counterweight, over full range																			
	Boom length (m)																			
3	110*	100*	90																	
3.5	105*	95*	87	75																
4	100*	90	83	75																
4.5	91*	85	78	75	60															
5	84	80	73	70	58															
5.5	78	75	68	65	55	45														
6	71	70	63	60	52	45														
7	57	56	56	55	49	45	35													
8	48	48	48	47	46	43	33													
9	41	41	41	41	42	41	30.5	28												
10		35	36	36	36.5	37.5	29	28												
11		30	31	30	30.5	32	27.5	26	23											
12		26	27	26	26.5	27.5	25.8	24	21.5	19										
14			20.5	19.5	20	21.5	22	21.2	19	17	15									
16				16	15	15.5	17	17.5	17	17	15.4	13.5	12							
18						12	12.5	13.5	14.3	13.8	13.6	13.8	12.5	11	9					
20							9.5	10.5	11	12	11	11.2	11.5	10.1	8.2	7				
22								8.5	9.3	10	9.4	9.6	10	9.3	7.6	6.5				
24								7	7.8	8.5	8	8	8.2	8.5	8.5	7.1	6.1			
26									6.6	7.3	6.7	6.7	6.9	7.2	7.5	6.6	5.7			
28										5.5	6.2	5.7	5.7	5.9	6.2	6.5	6.1	5.4		
30											5.3	4.8	4.8	4.9	5.2	5.5	5.6	5.1		
32												4.5	4	4	4.1	4.4	4.7	5.1	4.8	
34													3.3	3.3	3.4	3.7	4.1	4.5	4.5	
36														2.6	2.6	2.7	3	3.4	3.8	3.8
38															2.1	2.2	2.5	2.9	3.3	3.3
40															1.6	1.7	2	2.4	2.8	2.8
42																1.2	1.5	1.9	2.3	2.3
44																1.1	1.5	1.9	1.9	
46																	1.1	1.5	1.5	
48																		1.2	1.2	
Reeving	14	14	12	10	8	6	5	4	3	3	2	2	2	2	2	2	2	2	2	2
Hook	90 tons			55 tons				25 tons												
Telescoping mode	I	1	1	1	2	2	2	3	3	3	3	3	3	3	3	4				
	II	1	2	2	2	2	2	2	2	3	3	3	3	3	3	4				

# ZAT1500 Rated lifting capacity table

Table 5 Main boom Unit: Metric tons

Outriggers fully extended, without counterweight, over full range															
Radius (m)	Boom length (m)														
	13.5	18	22.5	27	31.5	36	40.5	45	49.5	54	58.5	63	67.5	72	
3	105*	100*	90												
3.5	98*	95*	87	75											
4	90	90	83	75											
4.5	78	78	78	75	60										
5	69	69	69	68	58										
5.5	60	60	60	60	55	45									
6	52	52	52	52	48	45									
7	39	39	40	39	39	40	34								
8	29	29	30	29	30	31	31								
9	22	22	22	21.5	22	23	25	23							
10		18	18	17.5	18	19	20	19							
11		14.5	15	14	15	16	17	16	16						
12		11.5	12	11	12	13	14	13	13	13					
14			8.5	7.5	8.5	9.2	10	9.5	9.5	9.5	10				
16			6	5	6	6.5	7.2	6.6	6.6	6.8	7	7			
18				3.2	4	4.5	5.2	4.6	4.6	4.8	5	5	5		
20					1.8	2.6	3.5	4.2	3.6	3.6	3.8	4	4	4	
22						1.5	2.3	3	2.4	2.4	2.6	2.8	2.8	3.5	3.5
24							1.3	2.2	1.4	1.4	1.6	1.8	1.8	2.6	2.6
26								1.3				1.1	1.1	1.9	1.9
28														1.2	1.2
Reeving	14	14	12	10	8	6	5	3	3	2	2	2	2	2	2
Hook	90 tons			55 tons			25 tons								
Telescoping mode	I	1	1	2	2	2	2	3	3	3	3	3	3	4	
	II	1	2	2	2	2	2	2	3	3	3	3	3	4	
	III	1	1	2	2	2	2	2	2	3	3	3	3	4	
	IV	1	1	1	1	2	2	2	2	2	3	3	3	4	
	V	1	1	1	1	1	2	2	2	2	2	3	3	4	
	VI	1	1	1	1	1	2	2	2	2	2	2	3	4	

Note: The data indicated with an asterisk (\*) are suitable for 110 tons hook.

Table 6 Main boom Unit: Metric tons

Outriggers intermediately extended, with 45 tons counterweight, over full range																				
Radius (m)	Boom length (m)																			
	13.5	18	22.5	27	31.5	36	40.5	45	49.5	54	58.5	63	67.5	72						
3	110*	100*	90																	
3.5	104*	95*	87	75																
4	96*	90	83	75																
4.5	88	85	78	75	60															
5	82	80	73	70	58															
5.5	76	75	68	65	55	45														
6	71	71	63	60	52	45														
7	58	58	56	56	49	45	35													
8	50	50	50	50	45	43	33													
9	42	40	40	40	41	40	30.5	28												
10		35	35	35	35	35	29	28												
11		30	30	29.5	29.5	30.5	27.5	26	23											
12		26	26	26	26	26.5	25.5	24	21.5	19										
14			20	19.5	20	21	21	20.5	19	17	15									
16				16	15.5	15.5	16.5	17.5	16.5	16	15.4	13.5	12							
18					12.5	12.5	13.5	14.5	14	14	13.5	12.5	11	9						
20						10.5	11	11.5	12	11.5	11.5	11.7	10.1	8.2	7					
22							9	9.5	10	9.6	9.6	9.7	9.5	9.3	7.6	6.5				
24								7.5	8	8.8	8.4	8.2	8.3	8.5	8.4	7.1	6.1			
26									7	7.7	7.2	7	7.2	7.4	7.4	6.6	5.7			
28									6	6.7	6.2	6	6.1	6.4	6.6	6.1	5.4			
30										5.5	5.1	5	5.1	5.4	5.8	5.6	5.1			
32										5	4.4	4.3	4.4	4.7	5.1	5.4	4.7			
34											3.5	3.4	3.6	3.9	4.3	4.6	4.6			
36												2.9	2.8	3.0	3.3	3.7	4.1	4.1		
38													2.3	2.5	2.8	3.1	3.5	3.5		
40														1.8	2.0	2.3	2.6	3.0	3.0	
42															1.5	1.9	2.1	2.5	2.5	
44																1.4	1.7	2.0	2.0	
46																	1.4	1.7	1.7	
48																		1.4	1.4	
Reeving	14	14	12	10	8	6	5	4	3	3	2	2	2	2	2	2	2	2	2	
Hook	90 tons			55 tons			25 tons													
Telescoping mode	I	1	1	1	2	2	2	2	3	3	3	3	3	3	3	4				
	II	1	2	2	2	2	2	2	2	3	3	3	3	3	3	4				
	III	1	1	2	2	2	2	2	2	2	3	3	3	3	3	4				
	IV	1	1	1	1	2	2	2	2	2	2	2	2	2	3	3	4			
	V	1	1	1	1	1	2	2	2	2	2	2	2	2	2	3	3	4		
	VI	1	1	1	1	1	1	2	2	2	2	2	2	2	2	2	3	4		

Note: The data indicated with an asterisk (\*) are suitable for 110 tons hook.

# ZAT1500 Rated lifting capacity table

Table 7 Main boom Unit: Metric tons

Outriggers intermediately extended, with 32 tons counterweight, over full range																				
Radius (m)	Boom length (m)																			
	13.5	18	22.5	27	31.5	36	40.5	45	49.5	54	58.5	63	67.5	72						
3	110*	100*	90																	
3.5	102*	95*	87	75																
4	93*	90	83	75																
4.5	84	84	78	75	60															
5	77	77	73	70	58															
5.5	72	72	68	65	55	45														
6	63	63	63	60	52	45														
7	51	51	51	52	48	45	35													
8	42	42	43	42	43	43	33													
9	34	34	35	34	35	36	30.5	28												
10		28	29	28	29	30	28.5	28												
11		24	25	24	25	26	26.5	26	23											
12		20	21	20	21	22	23	22.5	21.5	19										
14			16	15.2	16	17	18	17.5	17.5	17	15									
16				12.5	11.7	12.5	13.5	14.3	13.8	13.8	14	13.5	12							
18					9.2	10	11	11.4	10.8	10.8	11	11.3	11	9						
20						7.4	8.2	9	9.5	9	9.2	9.5	9.8	8.2	7					
22							6.5	7.3	8	7.3	7.3	7.5	7.7	8.2	7.4	6.5				
24								5.3	6	6.6	6.1	6.1	6.3	6.5	7	6.6	6			
26									5	5.5	5	5	5.2	5.5	5.8	5.8	5.5			
28									4	4.6	4.1	4.1	4.3	4.5	4.8	5	5			
30										3.8	3.3	3.3	3.5	3.7	4.1	4.5	4.5			
32											3.1	2.6	2.6	2.8	3	3.3	3.7	3.7		
34												1.9	1.9	2.1	2.3	2.6	3	3		
36													1.4	1.4	1.6	1.8	2.1	2.5	2.5	
38														1.1	1.3	1.6	2	2		
40															1.2	1.6	1.6			
42																1.2	1.2			
Reeving	14	14	12	10	8	6	5	4	3	3	2	2	2	2	2	2	2	2	2	
Hook	90 tons			55 tons			25 tons													
Telescoping mode	I	1	1	1	2	2	2	2	3	3	3	3	3	3	3	4				
	II	1	2	2	2	2	2	2	2	3	3	3	3	3	3	4				
	III	1	1	2	2	2	2	2	2	2	3	3	3	3	3	4				
	IV	1	1	1	1	2	2	2	2	2	2	2	2	2	3	3	4			
	V	1	1	1	1	1	2	2	2	2	2	2	2	2	2	3	3	4		
	VI	1	1	1	1	1	1	2	2	2	2	2	2	2	2	2	3	4		

Note: The data indicated with an asterisk (\*) are suitable for 110 tons hook.

Table 8 Main boom Unit: Metric tons

Outriggers intermediately extended, with 24 tons counterweight, over full range														
Radius (m)	Boom length (m)													
	13.5	18	22.5	27	31.5	36	40.5	45	49.5	54	58.5	63	67.5	72
3	110*	100*	90											
3.5	101*	95*	87	75										
4	92*	90	83	75										
4.5	83	83	78	75	60									
5	75	75	73	70	58									
5.5	67	67	66	65	55	45								
6	58	58	58	57	52	45								
7	45	45	45	44	44	44	35							
8	35	35	36	35	35									

# ZAT1500 Rated lifting capacity table

Table 9 Main boom Unit: Metric tons

Outriggers intermediately extended, with 10 tons counterweight, over full range															
Radius (m)	Boom length (m)														
	13.5	18	22.5	27	31.5	36	40.5	45	49.5	54	58.5	63	67.5	72	
3	100*	100*	90												
3.5	90	90	84	75											
4	80	80	75	70											
4.5	63	63	62	58	58										
5	54	54	53	53	53										
5.5	45	45	44	42	42	42									
6	40	40	39	38	38	38									
7	29	29	29	29	29	29	28								
8	22	22	23	22	23	23	23								
9	17	17	18	17	18	18.5	19	18							
10		14	15	14	15	15.5	16	15							
11		11	12	11	12	12.5	13	12	12						
12		9	10	9	10	10.5	11	10	10						
14			7	6.2	7.2	7.7	8.4	8	8	8					
16			4.7	4.2	5	5.5	6.2	5.8	5.8	6	6	6			
18				2.5	3.3	4	4.5	4	3.8	4	4.4	4.7	5		
20					1.3	2	2.6	3.4	2.8	2.8	3	3.2	3.5	4	
22						1.6	2.4	1.8	1.8	2	2.2	2.5	3	3	
24							1.5			1.1	1.4	1.6	2	2	
26												1.1	1.4	1.4	
Reeving	14	14	12	10	8	6	4	3	2	2	2	2	2	2	
Hook	90 tons				55 tons				25 tons						
Telescoping mode	I	1	1	1	2	2	2	2	3	3	3	3	3	4	
	II	1	2	2	2	2	2	2	3	3	3	3	3	4	
	III	1	1	2	2	2	2	2	2	3	3	3	3	4	
	IV	1	1	1	1	2	2	2	2	2	3	3	3	4	
	V	1	1	1	1	1	2	2	2	2	2	3	3	4	
	VI	1	1	1	1	1	2	2	2	2	2	2	3	4	

Note: The data indicated with an asterisk (\*) are suitable for 110 tons hook.

Table 10 Main boom + jib Unit: Metric tons

Outriggers fully extended (7.8 m), with 45 tons counterweight, over full range				
Jib length	11.0 m			
Main boom length	63.0 m	67.5 m		
Boom angle	0°	30°	0°	30°
82°	6.5	4.5	5.5	4
80°	6.5	4.4	5.5	3.9
78°	6.5	4.3	5.5	3.8
76°	6.2	4.2	5.2	3.7
74°	5.9	4.1	4.8	3.6
72°	5.6	4	4.5	3.5
70°	5.2	3.9	4.2	3.4
68°	4.8	3.8	3.9	3.3
66°	4.5	3.7	3.6	3.1
64°	4.2	3.6	3.3	2.9
62°	3.9	3.4	3.1	2.8
60°	3.6	3.2	2.9	2.6
58°	3.4	3.0	2.7	2.4
56°	3.2	2.8	2.5	2.3
54°	3.0	2.7	2.4	2.2
52°	2.7	2.5	2.2	2.0
50°	2.5	2.3	2.0	1.9
48°	2.1	2.0	1.8	1.7
46°	1.9	1.8	1.6	1.5
44°	1.7	1.6	1.4	1.3
42°	1.5	1.4	1.2	1.1
40°	1.3	1.2		
Reeving	1			
Hook	7 tons			
Telescoping mode	I	3	3	3
	II	3	3	3
	III	3	3	3
	IV	3	3	3
	V	3	3	3
	VI	2	2	3

Table 11 Main boom + jib Unit: Metric tons

Outriggers fully extended (7.8 m), with 32 tons counterweight, over full range				
Jib length	11.0 m			
Main boom length	63.0 m	67.5 m		
Boom angle	0°	30°	0°	30°
82°	6.5	4.5	5.5	4
80°	6.5	4.4	5.5	3.9
78°	6.5	4.3	5.5	3.8
76°	6.2	4.2	5.2	3.7
74°	5.9	4.1	4.8	3.6
72°	5.6	4.0	4.5	3.5
70°	5.2	3.9	4.2	3.4
68°	4.8	3.8	3.9	3.3
66°	4.5	3.7	3.6	3.1
64°	4.2	3.6	3.3	2.9
62°	3.8	3.4	3.1	2.8
60°	3.4	3.1	2.8	2.6
58°	3.0	2.8	2.6	2.3
56°	2.6	2.5	2.3	2.1
54°	2.3	2.1	1.9	1.8
52°	2.0	1.8	1.6	1.5
50°	1.7	1.5	1.4	1.3
48°	1.5	1.3	1.1	1.0
46°	1.2	1.1		
44°	1.0	0.9		
Reeving	1			
Hook	7 tons			
Telescoping mode	I	3	3	3
	II	3	3	3
	III	3	3	3
	IV	3	3	3
	V	3	3	3
	VI	2	2	3

# ZAT1500 Rated lifting capacity table

Table 12 Main boom + jib Unit: Metric tons

Outriggers fully extended (7.8 m), with 24 tons counterweight, over full range				
Jib length	11.0 m			
Main boom length	63.0 m	67.5 m		
Boom angle	0°	30°	0°	30°
82°	6.5	4.5	5.5	4
80°	6.5	4.4	5.5	3.9
78°	6.5	4.3	5.5	3.8
76°	6.2	4.2	5.2	3.7
74°	5.9	4.1	4.8	3.6
72°	5.6	4.0	4.5	3.5
70°	5.2	3.9	4.2	3.4
68°	4.7	3.8	3.9	3.3
66°	4.2	3.6	3.5	3.0
64°	3.6	3.2	3.1	2.8
62°	3.1	2.8	2.6	2.4
60°	2.6	2.4	2.2	2.0
58°	2.2	2.0	1.8	1.7
56°	1.8	1.7	1.5	1.4
54°	1.5	1.4	1.2	1.1
52°	1.2	1.1		
Reeving	1			
Hook	7 tons			
Telescoping mode	I	3	3	3
	II	3	3	3
	III	3	3	3
	IV	3	3	3
	V	3	3	3
	VI	2	2	3

Table 13 Main boom + jib Unit: Metric tons

Outriggers fully extended (7.8 m), with 10 tons counterweight, over full range				
Jib length	11.0 m			
Main boom length	63.0 m	67.5 m		
Boom angle	0°	30°	0°	30°
82°	6.5	4.5	5.5	4
80°	6.5	4.5	5.5	3.9
78°	6.5	4.3	5.5	3.8
76°	6.2	4.2	5.2	3.7
74°	5.3	4.1	4.5	3.5
72°	4.3	3.6	3.7	3.1
70°	3.6	3.0	3.0	2.5
68°	2.9	2.4	2.4	2.0
66°	2.2	1.9	1.8	1.6
64°	1.7	1.4	1.3	1.1
62°	1.2	1.0		
Reeving	1			
Hook	7 tons			
Telescoping mode	I	3	3	3
	II	3	3	3
	III	3	3	3
	IV	3	3	3
	V	3	3	3
	VI	2	2	3

Table 14 Main boom + jib Unit: Metric tons

Outriggers fully extended (7.8 m), with 45 tons counterweight, over full range				
Jib length	18.6 m			
Main boom length	63.0 m	67.5 m		
Boom angle	0°	30°	0°	30°
82°	4.5	2.5	3.5	2.0
80°	4.3	2.5	3.5	2.0
78°	4.1	2.4	3.5	2.0
76°	3.9	2.4	3.3	1.9
74°	3.6	2.2	3.1	1.9
72°	3.3	2.1	2.9	1.8
70°	3.1	2.0	2.7	1.8
68°	2.9	1.9	2.5	1.7
66°	2.7	1.8	2.4	1.7
64°	2.5	1.8	2.2	1.6
62°	2.4	1.7	2.0	1.5
60°	2.2	1.7	1.9	1.5
58°	2.1	1.6	1.7	1.4
56°	2.0	1.6	1.6	1.4
54°	1.9	1.5	1.5	1.3
52°	1.8	1.5	1.4	1.2
50°	1.7	1.4	1.3	1.1
48°	1.5	1.3	1.2	1.0
46°	1.2	1.1		
Reeving	1			
Hook	7 tons			
Telescoping mode	I	3	3	3
	II	3	3	3
	III	3	3	3
	IV	3	3	3
	V	3	3	3
	VI	2	2	3

Table 15 Main boom + jib Unit: Metric tons

Outriggers fully extended (7.8 m), with 32 tons counterweight, over full range				
Jib length	18.6 m			
Main boom length	63.0 m	67.5 m		
Boom angle	0°	30°	0°	30°
82°	4.5	2.5	3.5	2.0
80°	4.3	2.5	3.5	2.0
78°	4.1	2.4	3.5	2.0
76°	3.9	2.4	3.3	1.9
74°	3.6	2.2	3.1	1.9
72°	3.3	2.1	2.9	1.8
70°	3.1	2.0	2.7	1.8
68°	2.9	1.9	2.5	1.7
66°	2.7	1.8	2.4	1.7
64°	2.5	1.8	2.2	1.6
62°	2.4	1.7	2.0	1.5
60°	2.2	1.7	1.9	1.5
58°	2.0	1.6	1.7	1.4
56°	1.8	1.5	1.5	1.3
54°	1.5	1.3	1.2	1.0
52°	1.2	1.1		
Reeving	1			
Hook	7 tons			
Telescoping mode	I	3	3	3
	II	3	3	3
	III	3	3	3
	IV	3	3	3
	V	3	3	3
	VI	2	2	3

# ZAT1500 Rated lifting capacity table

Table 16 Main boom + jib Unit: Metric tons

Outriggers fully extended (7.8 m), with 24 tons counterweight, over full range					
Jib length	18.6 m				
Main boom length	63.0 m		67.5 m		
Boom angle	0°	30°	0°	30°	30°
82°	4.5	2.5	3.5	2.0	
80°	4.3	2.5	3.5	2.0	
78°	4.1	2.4	3.5	2.0	
76°	3.9	2.4	3.3	1.9	
74°	3.6	2.2	3.1	1.9	
72°	3.3	2.1	2.9	1.8	
70°	3.1	2.0	2.7	1.8	
68°	2.9	1.9	2.5	1.7	
66°	2.7	1.8	2.4	1.7	
64°	2.4	1.8	2.1	1.6	
62°	2.1	1.7	1.8	1.4	
60°	1.8	1.6	1.4	1.2	
58°	1.4	1.2			
56°	1.1				
Reeving Hook	1 7 tons				
Telescoping mode	I	3	3	3	3
	II	3	3	3	3
	III	3	3	3	3
	IV	3	3	3	3
	V	3	3	3	3
	VI	2	2	3	3

Table 17 Main boom + jib Unit: Metric tons

Outriggers fully extended (7.8 m), with 10 tons counterweight, over full range					
Jib length	18.6 m				
Main boom length	63.0 m		67.5 m		
Boom angle	0°	30°	0°	30°	30°
82°	4.5	2.5	3.5	2.0	
80°	4.3	2.5	3.5	2.0	
78°	4.1	2.4	3.5	2.0	
76°	3.9	2.4	3.3	1.9	
74°	3.5	2.2	3.1	1.8	
72°	3.2	2.1	2.6	1.7	
70°	2.6	1.9	2.1	1.6	
68°	2.0	1.5	1.6	1.2	
66°	1.5	1.1			
Reeving Hook	1 7 tons				
Telescoping mode	I	3	3	3	3
	II	3	3	3	3
	III	3	3	3	3
	IV	3	3	3	3
	V	3	3	3	3
	VI	2	2	3	3

Table 18 Main boom + jib Unit: Metric tons

Outriggers fully extended (7.8 m), with 45 tons counterweight, over full range					
Jib length	26.6 m				
Main boom length	63.0 m		67.5 m		
Boom angle	0°	30°	0°	30°	30°
82°	2.5		2.0		
80°	2.5		2.0		
78°	2.5		2.0		
76°	2.3		1.9		
74°	2.1		1.8		
72°	1.9		1.7		
70°	1.8		1.6		
68°	1.7		1.5		
66°	1.6		1.4		
64°	1.5		1.3		
62°	1.4		1.2		
60°	1.3		1.1		
58°	1.2		1.0		
56°	1.1				
54°	1.0				
Reeving Hook	1 7 tons				
Telescoping mode	I	3		3	
	II	3		3	
	III	3		3	
	IV	3		3	
	V	3		3	
	VI	2		3	

Table 19 Main boom + jib Unit: Metric tons

Outriggers fully extended (7.8 m), with 32 tons counterweight, over full range					
Jib length	26.6 m				
Main boom length	63.0 m		67.5 m		
Boom angle	0°	30°	0°	30°	30°
82°	2.5		2.0		
80°	2.5		2.0		
78°	2.5		2.0		
76°	2.3		1.9		
74°	2.1		1.8		
72°	1.9		1.7		
70°	1.8		1.6		
68°	1.7		1.5		
66°	1.6		1.4		
64°	1.5		1.3		
62°	1.4		1.2		
60°	1.3		1.1		
58°	1.2				
56°	1.1				
Reeving Hook	1 7 tons				
Telescoping mode	I	3		3	
	II	3		3	
	III	3		3	
	IV	3		3	
	V	3		3	
	VI	2		3	

# ZAT1500 Rated lifting capacity table

Table 24 Main boom + jib Unit: Metric tons

Outriggers intermediately extended (5.3 m), with 24 tons counterweight, over full range					
Jib length	11.0 m				
Main boom length	63.0 m		67.5 m		
Boom angle	0°	30°	0°	30°	30°
82°	6.5	4.5	5.5	4	
80°	6.5	4.4	5.5	3.9	
78°	6.5	4.3	5.5	3.8	
76°	6.2	4.2	5.2	3.6	
74°	5.3	4.1	4.5	3.4	
72°	4.4	3.6	3.7	3.1	
70°	3.6	3.1	3.0	2.5	
68°	2.9	2.5	2.4	2.0	
66°	2.3	2.0	1.9	1.6	
64°	1.7	1.5	1.4	1.2	
62°	1.3	1.1			
Reeving Hook	1 7 tons				
Telescoping mode	I	3	3	3	3
	II	3	3	3	3
	III	3	3	3	3
	IV	3	3	3	3
	V	3	3	3	3
	VI	2	2	3	3

Table 25 Main boom + jib Unit: Metric tons

Outriggers intermediately extended (5.3 m), with 45 tons counterweight, over full range					
Jib length	18.6 m				
Main boom length	63.0 m		67.5 m		
Boom angle	0°	30°	0°	30°	30°
82°	4.5	2.5	3.5	2.0	
80°	4.3	2.5	3.5	2.0	
78°	4.1	2.4	3.5	2.0	
76°	3.9	2.4	3.3	1.9	
74°	3.6	2.2	3.1	1.9	
72°	3.3	2.1	2.9	1.8	
70°	3.1	2.0	2.7	1.8	
68°	2.9	1.9	2.5	1.7	
66°	2.7	1.8	2.4	1.7	
64°	2.4	1.8	2.1	1.6	
62°	2.2	1.7	1.8	1.4	
60°	1.8	1.5	1.5	1.2	
58°	1.5	1.2	1.2	1.0	
56°	1.2	1.0			
Reeving Hook	1 7 tons				
Telescoping mode	I	3	3	3	3
	II	3	3	3	3
	III	3	3	3	3
	IV	3	3	3	3
	V	3	3	3	3
	VI	2	2	3	3

Table 26 Main boom + jib Unit: Metric tons

Outriggers intermediately extended (5.3 m), with 32 tons counterweight, over full range					
Jib length	18.6 m				
Main boom length	63.0 m		67.5 m		
Boom angle	0°	30°	0°	30°	30°
82°	4.5	2.5	3.5	2.0	
80°	4.3	2.5	3.5	2.0	
78°	4.1	2.4	3.5	2.0	
76°	3.9	2.4	3.3	1.9	
74°	3.6	2.2	3.1	1.9	
72°	3.3	2.1	2.8	1.8	
70°	3.1	2.0	2.6	1.7	
68°	2.7	1.8	2.4	1.6	
66°	2.3	1.7	1.9	1.5	
64°	1.9	1.5	1.5	1.2	
62°	1.5	1.2			
60°	1.1				
Reeving Hook	1 7 tons				
Telescoping mode	I	3	3	3	3
	II	3	3	3	3
	III	3	3	3	3
	IV	3	3	3	3
	V	3	3	3	3
	VI	2	2	3	3

Table 27 Main boom + jib Unit: Metric tons

Outriggers intermediately extended (5.3 m), with 24 tons counterweight, over full range					
Jib length	18.6 m				
Main boom length	63.0 m		67.5 m		
Boom angle	0°	30°	0°	30°	30°
82°	4.5	2.5	3.5	2.0	
80°	4.3	2.5	3.5	2.0	
78°	4.1	2.4	3.5	2.0	
76°	3.8	2.4	3.3	1.9	
74°	3.5	2.2	3.1	1.8	
72°	3.2	2.0	2.6	1.7	
70°	2.6	1.8	2.1	1.6	
68°	2.0	1.5	1.6	1.2	
66°	1.5	1.1			
Reeving Hook	1 7 tons				
Telescoping mode	I	3	3	3	3
	II	3	3	3	3
	III	3	3	3	3
	IV	3	3	3	3
	V	3	3	3	3
	VI	2	2	3	3

Table 20 Main boom + jib Unit: Metric tons

Outriggers fully extended (7.8 m), with 24 tons counterweight, over full range					
Jib length	26.6 m				
Main boom length	63.0 m		67.5 m		
Boom angle	0°	30°	0°	30°	30°
82°	2.5		2.0		
80°	2.5		2.0		
78°	2.5		2.0		
76°	2.3		1.9		
74°	2.1		1.8		
72°	1.9		1.7		
70°	1.8		1.6		
68°	1.7		1.5		
66°	1.6		1.4		
64°	1.5		1.3		
62°	1.3		1.1		
60°	1.2				
Reeving Hook	1 7 tons				
Telescoping mode	I	3		3	
	II	3		3	
	III	3		3	
	IV	3		3	
	V	3		3	
	VI	2		3	

Table 21 Main boom + jib Unit: Metric tons

Outriggers fully extended (7.8 m), with 10 tons counterweight, over full range					
Jib length	26.6 m				
Main boom length	63.0 m		67.5 m		
Boom angle	0°	30°	0°	30°	30°
82°	2.5		2.0		
80°	2.5		2.0		
78°	2.5		2.0		
76°	2.3		1.9		
74°	2.1		1.8		
72°	1.9		1.6		
70°	1.8		1.4		
68°	1.3				
Reeving Hook	1 7 tons				
Telescoping mode	I	3		3	
	II	3		3	
	III	3		3	
	IV	3		3	
	V	3		3	
	VI	2		3	

Table 22 Main boom + jib Unit: Metric tons

Outriggers intermediately extended (5.3 m), with 45 tons counterweight, over full range					
Jib length	11.0 m				
Main boom length	63.0 m		67.5 m		
Boom angle	0°	30°	0°	30°	30°
82°	6.5	4.5	5.5	4	
80°	6.5	4.5	5.5	3.9	
78°	6.5	4.3	5.5	3.8	
76°	6.2	4.2	5.2	3.7	
74°	5.9	4.1	4.8	3.6	
72°	5.6	4.0	4.5	3.5	
70°	5.2	3.9	4.2	3.4	
68°	4.7	3.8	3.9	3.2	
66°	4.1	3.6	3.5	3.0	
64°	3.6	3.2	3.1	2.8	
62°	3.1	2.8	2.7	2.4	
60°	2.6	2.4	2.2	2.0	
58°	2.2	2.0	1.9	1.7	
56°	1.8	1.6	1.5	1.4	
54°	1.5	1.3	1.2	1.1	
52°	1.2	1.0			
Reeving Hook	1 7 tons				
Telescoping mode	I	3	3	3	3
	II	3	3	3	3
	III	3	3	3	3
	IV	3	3	3	3
	V	3	3	3	3
	VI	2	2	3	3

Table 23 Main boom + jib Unit: Metric tons

Outriggers intermediately extended (5.3 m), with 32 tons counterweight, over full range					
Jib length	11.0 m				
Main boom length	63.0 m		67.5 m		
Boom angle	0°	30°	0°	30°	30°
82°	6.5	4.5	5.5	4	
80°	6.5	4.4	5.		



# ZAT1500 Rated lifting capacity table

Table 31 Main boom + tip boom Unit: Metric tons

Outriggers fully extended (7.8 m), with 45 tons counterweight, over full range															
Radius (m)	Boom length (m)														
	13.5	18.0	22.5	27.0	31.5	36.0	40.5	45.0	49.5	54.0	58.5	63.0	67.5	72	
3.0	28														
3.5	27	27													
4.0	26.5	26.5	27												
4.5	26	26	26.5												
5.0	25.5	25.5	26	27											
5.5	25	25	25.5	26.5											
6.0	24.5	24.5	25	26	26										
7.0	23.5	24	24.5	25.5	26	24									
8.0	22.5	23.5	24	25	25.5	24	22								
9.0	21.5	23	23.5	24.5	25	24	21								
10.0	20.5	22.5	23	24	24.5	24	20	20							
11.0	20	22	22.5	23.5	24	23.5	19	19	18						
12.0	19.5	21.5	22	23	23.5	23	18	18	17	15					
14.0		20.5	21.5	22.5	23	22.5	16.5	17	16	14	12				
16.0		19.5	20.5	21.5	22	21.5	15	16	15	13	11	9			
18.0			19.5	19	19.5	19.5	14	15	14	12	10.4	8.5	7		
20.0			16.5	16	16.5	16.5	13	14	12.5	11	9.8	8	6.6	5	
22.0			13	14	14.5	12	12.5	11.5	10.2	9.2	7.5	6.3	5		
24.0				11	12	12.5	11	11.5	10.5	9.4	8.6	7.2	6	5	
26.0					10	10.5	10.5	9.5	8.7	8	6.9	5.7	4.8		
28.0					8.5	9	9.5	9.2	8.6	8	7.4	6.6	5.4	4.5	
30.0						8	8.5	8.2	7.8	7.4	6.9	6.3	5.1	4.3	
32.0						7	7.5	7.2	7.2	6.8	6.4	5.8	4.8	4.1	
34.0							6.5	6.2	6.2	5.9	5.4	4.5	3.9		
36.0							5.7	5.4	5.4	5.6	5.4	5.1	4.2	3.7	
38.0								4.6	4.6	4.8	4.9	4.7	3.9	3.5	
40.0								4	4	4.2	4.4	4.3	3.6	3.3	
42.0									3.4	3.6	3.8	4	3.4	3.1	
44.0									2.9	3.1	3.3	3.6	3.2	2.9	
46.0										2.6	2.8	3.1	3	2.7	
48.0										2.2	2.4	2.7	2.8	2.5	
50.0											2	2.3	2.5	2.3	
52.0											1.6	2	2.2	2.1	
54.0												1.6	1.9	1.9	
56.0												1.3	1.6	1.7	
58.0													1.3	1.4	
60.0														1.1	
Reeving	4	4	4	4	4	3	3	3	3	3	2	2	2	2	
Hook	55 tons							25 tons							
Telescoping mode	I	1	1	1	2	2	2	3	3	3	3	3	3	4	
	II	1	2	2	2	2	2	3	3	3	3	3	3	4	
	III	1	1	2	2	2	2	2	3	3	3	3	3	4	
	IV	1	1	1	2	2	2	2	2	3	3	3	3	4	
	V	1	1	1	1	1	2	2	2	2	3	3	3	4	
	VI	1	1	1	1	1	2	2	2	2	2	3	3	4	

Table 32 Main boom + tip boom Unit: Metric tons

Outriggers fully extended (7.8 m), with 32 tons counterweight, over full range																	
Radius (m)	Boom length (m)																
	13.5	18.0	22.5	27.0	31.5	36.0	40.5	45.0	49.5	54.0	58.5	63.0	67.5	72			
3.0	28																
3.5	27	27															
4.0	26.5	26.5	27														
4.5	26	26	26.5														
5.0	25.5	25.5	26	27													
5.5	25	25	25.5	26.5													
6.0	24.5	24.5	25	26	26												
7.0	23.5	24	24.5	25.5	26	24											
8.0	22.5	23.5	24	25	25.5	24	22										
9.0	21.5	23	23.5	24.5	25	24	21										
10.0	20.5	22.5	23	24	24.5	24	20	20									
11.0	20	22	22.5	23.5	24	23.5	19	19	18								
12.0	19.5	21.5	22	23	23.5	23	18	18	17	15							
14.0		20.5	21.5	22.5	23	22.5	16.5	17	16	14	12						
16.0		19.5	20.5	20.5	21	21	15	16	15	13	11	9					
18.0			17.2	16.7	17.2	17.5	14	15	14	12	10.4	8.5	7				
20.0			14	13.5	14.1	14.5	13	13.5	12.5	11	9.8	8	6.6	5			
22.0				11	11.6	12	11.8	12	11.5	10.2	9.2	7.5	6.3	5			
24.0					9.4	10	10.4	10.8	10.5	10.3	9.4	8.6	7.2	6	5		
26.0						8.4	9	9.5	9.2	9	8.7	8	6.9	5.7	4.8		
28.0							7.2	7.8	8.4	8.0	7.9	8	7.4	6.6	5.4	4.5	
30.0								6.6	7.3	6.8	6.7	6.8	6.7	6.3	5.1	4.3	
32.0								5.7	6.4	5.9	5.8	5.9	6	5.7	4.8	4.1	
34.0									5.5	5.1	5	5.1	5.3	5.2	4.5	3.9	
36.0									4.7	4.3	4.2	4.3	4.6	4.6	4.2	3.7	
38.0										3.6	3.6	3.7	4	4	3.9	3.5	
40.0											3	3	3.1	3.3	3.6	3.3	
42.0											2.4	2.5	2.7	2.7	3.3	3.1	
44.0											1.9	2.1	2.3	2.3	2.8	2.8	
46.0												1.6	1.8	1.8	2.5	2.5	
48.0													1.2	1.4	1.4	2.1	2.1
50.0														1.1	1.1	1.7	1.7
52.0															1.4	1.4	
54.0																1.1	1.1
56.0																	
58.0																	
60.0																	
Reeving	4	4	4	4	4	3	3	3	3	3	2	2	2	2	2	2	2
Hook	55 tons							25 tons									
Telescoping mode	I	1	1	1	2	2	2	2	3	3	3	3	3	3	4		
	II	1	2	2	2	2	2	2	2	3	3	3	3	3	4		
	III	1	1	2	2	2	2	2	2	2	3	3	3	3	4		
	IV	1	1	1	2	2	2	2	2	2	3	3	3	3	4		
	V	1	1	1	1	1	2	2	2	2	2	3	3	3	4		
	VI	1	1	1	1	1	2	2	2	2	2	2	3	3	4		

# ZAT1500 Rated lifting capacity table

Table 33 Main boom + tip boom Unit: Metric tons

Outriggers fully extended (7.8 m), with 24 tons counterweight, over full range																			
Radius (m)	Boom length (m)																		
	13.5	18.0	22.5	27.0	31.5	36.0	40.5	45.0	49.5	54.0	58.5	63.0	67.5	72					
3.0	28																		
3.5	27	27																	
4.0	26.5	26.5	27																
4.5	26	26	26.5																
5.0	25.5	25.5	26	27															
5.5	25	25	25.5	26.5															
6.0	24.5	24.5	25	26	26														
7.0	23.5	24	24.5	25.5	26	24													
8.0	22.5	23.5	24	25	25.5	24	22												
9.0	21.5	23	23.5	24.5	25	24	21												
10.0	20.5	22.5	23	24	24.5	24	20	20											
11.0	20	22	22.5	23.5	24	23.5	19	19	18										
12.0	19.5	21.5	22	23	23.5	23	18	18	17	15									
14.0		20.5	21	21.5	22	22	16.5	17	16	14	12								
16.0		17	17.5	17	17.5	18	15	16	15	13	11	9							
18.0			14	13.5	14	14.5	14	14.5	13.5	12	10.4	8.5	7						
20.0				11.5	11	11.5	12	12.5	12	12	11	9.8	8	6.6	5				
22.0					9	9.5	10	10.5	10	10	9.2	7.5	6.3	5					
24.0						7.6	8.1	8.6	9.2	8.6	8.6	8.7	8.4	7.2	6	5			
26.0							6.7	7.2	7.8	7.3	7.3	7.4	7.6	6.9	5.7	4.8			
28.0								5.6	6.1	6.7	6.2	6.3	6.5	6.4	5.4	4.5			
30.0									5.1	5.7	5.2	5.2	5.3	5.5	5.8	5.1	4.3		
32.0									4.2	4.8	4.3	4.3	4.4	4.6	5	4.8	4.1		
34.0										4.1	3.6	3.6	3.7	3.9	4.3	4.5	3.9		
36.0											3.4	3	2.9	3	3.3	3.6	4	3.7	
38.0												2.4	2.3	2.4	2.7	3	3.4	3.4	
40.0													1.8	1.7	1.8	2.1	2.4	2.8	2.8
42.0																			

**ZAT1500** Lifting height chart

Main boom + 11 m jib

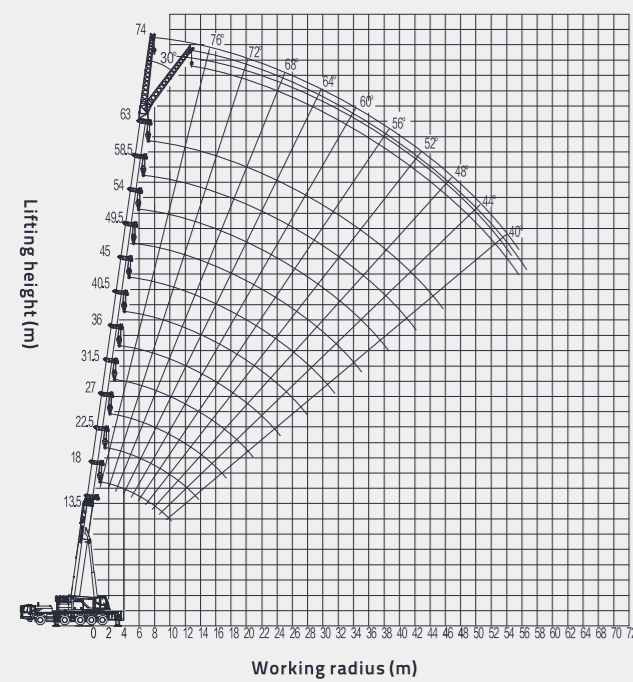

63 m main boom + 11 m jib

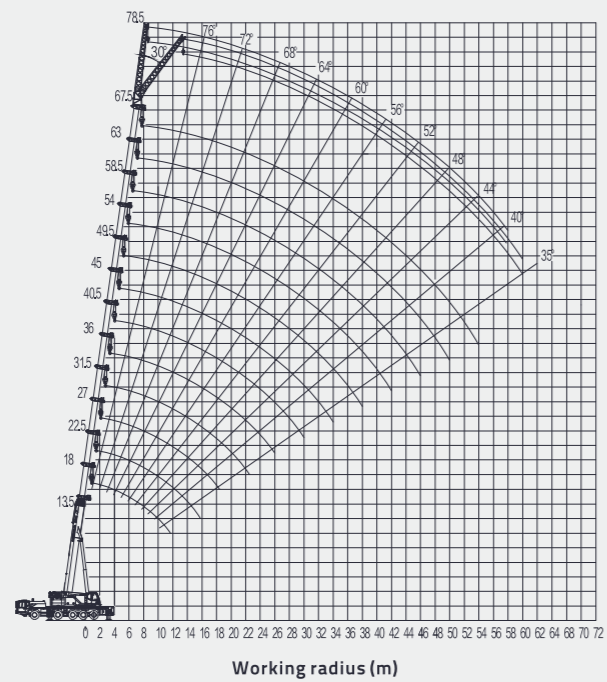

67.5 m main boom + 11 m jib

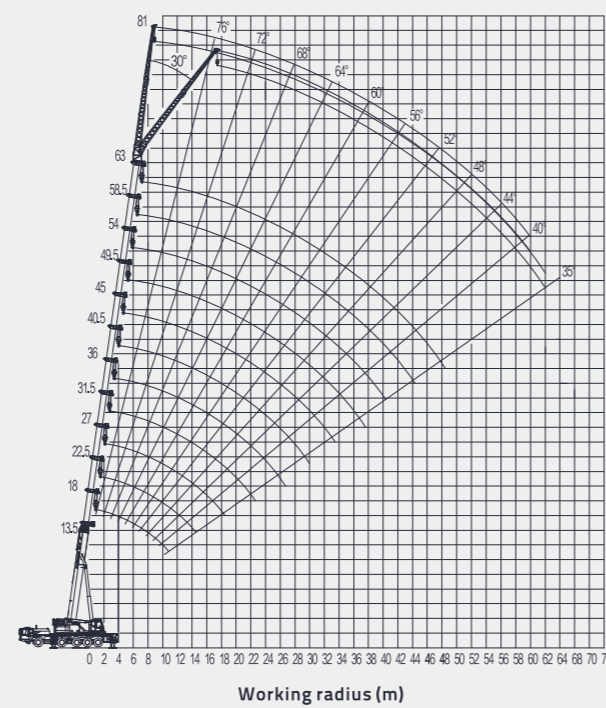

63 m main boom + 18.6 m jib

**ZAT1500** Lifting height chart

Main boom + 26.6 m jib

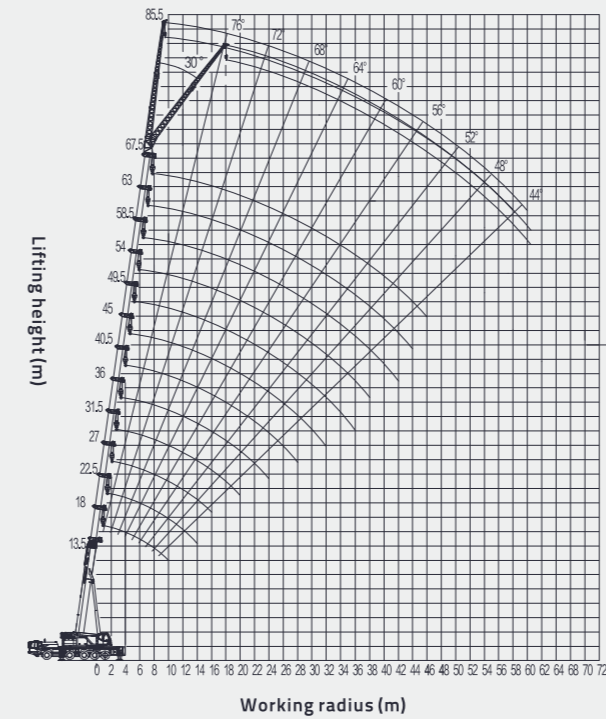

67.5 m main boom + 18.6 m jib

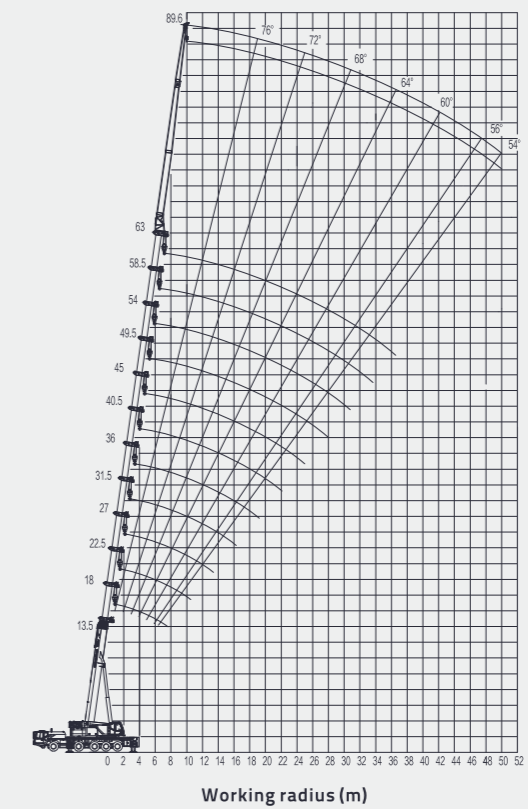

63 m main boom + 26.6 m jib

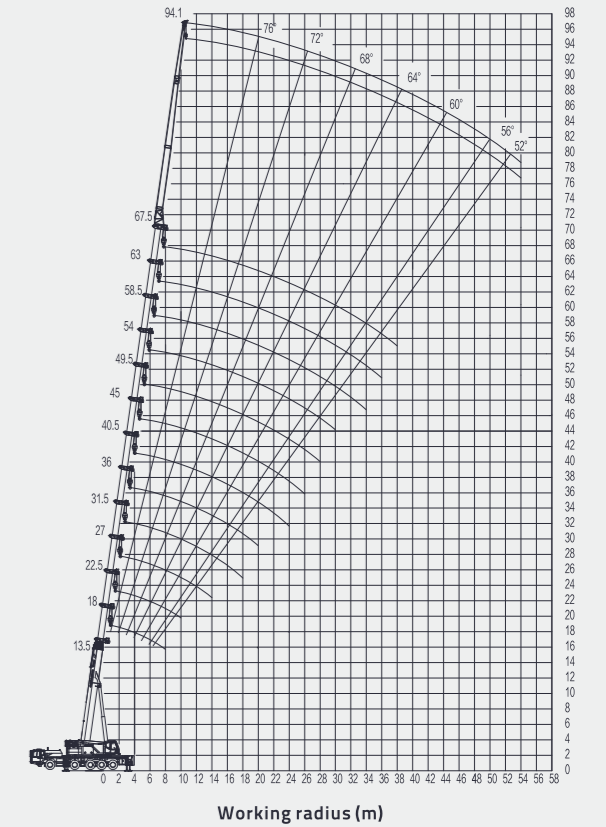

67.5 m main boom + 26.6 m jib